

Архангельск (8182)63-90-72
Астана (7172)727-132
Астрахань (8512)99-46-04
Барнаул (3852)73-04-60
Белгород (4722)40-23-64
Брянск (4832)59-03-52
Владивосток (423)249-28-31
Волгоград (844)278-03-48
Вологда (8172)26-41-59
Воронеж (473)204-51-73
Екатеринбург (343)384-55-89
Иваново (4932)77-34-06

Ижевск (3412)26-03-58
Иркутск (395)279-98-46
Казань (843)206-01-48
Калининград (4012)72-03-81
Калуга (4842)92-23-67
Кемерово (3842)65-04-62
Киров (8332)68-02-04
Краснодар (861)203-40-90
Красноярск (391)204-63-61
Курск (4712)77-13-04
Липецк (4742)52-20-81
Киргизия (996)312-96-26-47

Магнитогорск (3519)55-03-13
Москва (495)268-04-70
Мурманск (8152)59-64-93
Набережные Челны (8552)20-53-41
Нижний Новгород (831)429-08-12
Новокузнецк (3843)20-46-81
Новосибирск (383)227-86-73
Омск (3812)21-46-40
Орел (4862)44-53-42
Оренбург (3532)37-68-04
Пенза (8412)22-31-16
Казахстан (772)734-952-31

Пермь (342)205-81-47
Ростов-на-Дону (863)308-18-15
Рязань (4912)46-61-64
Самара (846)206-03-16
Санкт-Петербург (812)309-46-40
Саратов (845)249-38-78
Севастополь (8692)22-31-93
Симферополь (3652)67-13-56
Смоленск (4812)29-41-54
Сочи (862)225-72-31
Ставрополь (8652)20-65-13
Таджикистан (992)427-82-92-69

Сургут (3462)77-98-35
Тверь (4822)63-31-35
Томск (3822)98-41-53
Тула (4872)74-02-29
Тюмень (3452)66-21-18
Ульяновск (8422)24-23-59
Уфа (347)229-48-12
Хабаровск (4212)92-98-04
Челябинск (351)202-03-61
Череповец (8202)49-02-64
Ярославль (4852)69-52-93

<https://turck.nt-rt.ru/> || tku@nt-rt.ru

Temperature Sensors Industrial Temperature Measurement in Fluids and Gases



Температура

Благодаря простому программированию, гибким технологическим соединениям и дисплеям температурные датчики серии TS обеспечивают возможность создания адаптированных решений. Серии TTM/TTMS включают ряд компактных датчиков, поставляемых по дополнительному заказу со встроенным чувствительным элементом или разъемом M12 для отдельных чувствительных элементов. Инфракрасные датчики T-Gage обеспечивают бесконтактное измерение температуры в диапазоне 0–300°C. Серия TP включает температурные чувствительные элементы с различной длиной и диаметром.

Temperature Measurement – Overview

In order to operate machinery and equipment efficiently and safely, temperature has to be controlled continuously as a critical size in many industrial processes. Electronic temperature sensors and transmitters prove to be a reliable and practical solution for temperature detection not only due to their high accuracy and reproducibility, but also through a variety of interfaces to the process and to the operator.

In industrial applications, temperature is measured with resistance thermometers or thermocouples. Resistance thermometers accomplish this task via temperature-sensitive electrical thermistors. A distinction is made between PTC thermistors, whose resistance increases with increasing temperature and NTC thermistors with opposite behavior.

In combination with numerous connection options and variable output signals, the Turck portfolio guarantees maximum flexibility in terms of temperature measurement.



TS-400



TS-500

Ease of use

In addition of two buttons for quick menu scrolling, the TS series features a recessed button for secure storing of modified values.

Mounting flexibility

A rotatable sensor body with chamfered display, whose reading can be reversed by 180° degrees, can be mounted in many positions.

Accuracy

Thanks to an accuracy of 0.2 K, only a few types of temperature sensors are needed to handle many different applications.

Plant safety

The rugged stainless steel housing, excellent EMC properties and protection class IP67 provide highest operational safety.





TTMS...



T-Gage



IMS



TTM...



TP...



IM



IMX12

TS series

Through features such as easy programming, flexible process connection and a well readable display, the TS series provides everything you need to optimize your application.

TTM series

The compact sensors of the TTM series are available either with integrated probe or with a standard M12 plug connection to mount probes.

T-Gage

The infrared sensors of the T-Gage series measure temperatures contactless in a range between 0 and +300 °C and at wavelengths between 8 and 14 µm.

TP series

A further important device of the product portfolio is the IP67 rated Pt 100 resistance thermometer, used for temperatures between -50 and +500 °C. With regard to the temperature probes of the TP series, the user can choose from a comprehensive range of different probe lengths and diameters. When using a thermowell for protection, the temperature sensor can be adapted to critical application conditions.

IMS interface modules

The 1 and 2-channel IMS modules (Interface Modul Small) are only 6.2 mm slim and offer functions such as galvanic isolation, signal conditioning and temperature measurement.

IM interface modules

The 18 mm and 27 mm devices of the IM series can also be screwed on a panel. Thanks to a great variety of functions, these interface modules are suitable for many applications. In addition, the IM modules are equipped with a universal power supply unit that provides 20...250 VUC or 20...250 VAC/ 20...125 VDC for use with Ex-devices.

IMX-Interface modules

The new IMX12 interface modules offer up to two temperature input channels with a width of 12.5 mm. Extensive parameterization options allow adaptation to a wide range of applications. In addition to resistance temperature probes, thermocouples can also be connected.

Flexibility in any Applikation

Evaluation



TS-516



IM34



IMS



IMX12

End tip



Compact Probe
TP-103



Special Probe
TP-104



Cable Probe
TP-306

Process connection



Compression
Fitting
CF-...

Process



TS-Series



TTM-100



TTM-103A



TTMS-103A



Standard Probe
TP-203/206



Compression
Fitting
CF-...



Standard
Thermowell
THW-...



Special
Thermowell
THW-...

TS Series



- Accuracy ± 0.2 K
- Sensor rotatable by 320°
- Connection of temperature probes via M12 x 1 male
- stainless steel 1.4305 (AISI 303)
- Permanent display of temperature ($^\circ\text{C}$, $^\circ\text{F}$, K, Ω)
- Storage of max/min values
- Protection class IP67

The processing units of the TS-400/TS-500 series are incorporated in a non-rotatable, rugged stainless steel housing. A standard M12 x 1 plug connection is available for TP temperature probes. The display indicates the temperature during normal operation and guides the operator through the programming menu. We offer sensors with switching outputs or with a combination of switching and analog outputs.



TS - 5 00 - LIU2PN 8 X - H1 1 4 1

TS Functional principle - **5 00** Mechanical version - **LIU2PN 8 X** Electrical version -

Design
TS temperature sensor

Process connection
00 without process connection temperature probe via M12 x 1 male
16 G $\frac{1}{2}$ " with integrated probe
30 $\frac{1}{2}$ " NPT with integrated probe
only with design 5

Design
4 adjustable, with display non-rotatable
5 adjustable, with display non-rotatable

LED display
Operating voltage
8 15 (18)...30 VDC
Output type
2UPN 2 Schaltausgange
LUUPN Schalt- und Spannungsausgang
LIU2PN Strom- und Schaltausgang

H1 1 4 1 Electrical connection: male

Assignment
1 Belegung nach Norm
 andere: Sonderbelegung

standard assignment other special assignments
4 four

Connector type
1 straight

Connector type
H1 M12 x 1 male

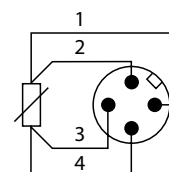
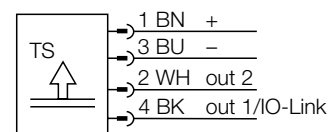
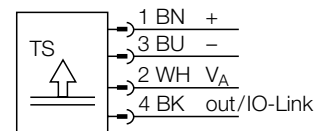
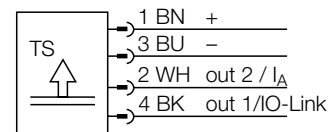

TTM Series



- Accuracy ± 0.2 K
- Protection class IP67
- Stainless steel 1.4404 (AISI 316L)
- Analog current output 4...20 mA (2-wire)
- Adjustment range -210...+650 °C

Miniature sensors of the TTM series fit in the most confined spaces and measure temperatures precisely via the integrated processor and the Platinum class A measuring element. Being only 25 mm longer and 1.5 mm wider than a standard M12 x 1 male, the fully encapsulated TTMs without processor provide an output signal of 4...20 mA in 2-wire technology. We also provide customized solutions on request.



TTM - 100C - 203A - CF - LI6 - H1 1 4 0 - L100

TTM Functional principle - **100C** Measuring range - **203A** Probe -

Design

- TTM** Temperature transmitter miniature
- TTMS** Temperature transmitter miniature stainless steel

Measuring range (other on request)

- 50C** 0...50 °C
- 100C** 0...100 °C
- 150C** 0...150 °C
- blank** freely adjustable via IO-Link

Design

- 100** processing unit without probe, connection via M12 x 1 male
- 103A** processing unit with probe \varnothing 3 mm, process connection via standard thread accuracy class A
- 203A** compression fitting/thermowell, probe \varnothing 3 mm, accuracy class A
- 206A** compression fitting/thermowell, probe \varnothing 6 mm

CF Process connection - **LI6** Electrical version -

Process connection

- G1/8** G1/8"-male thread (nur 103A)
- CF** Connection via clamping ring (only 203A and 206A)
- blank** probe connected via M12

Electrical version

- LI6** 4...20 mA 2-wire
- LIUPN** 4...20 mA 2-wire switching output PNP/NPN IO-Link

H1 1 4 0 Electrical connection - **L100** Probe length

Assignment

- 0** PIN1+ PIN2-

Number of contacts

- 4** four

Connector type

- 1** straight

Connector type

- H1** M12 x 1 male

Probe length mm

- L013** 13 mm (only 103A)
- L024** 24 mm (only 103A)
- L100** 100 mm
- L150** 150 mm

Customized lengths on request!

LI6

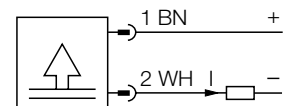

LIUPN

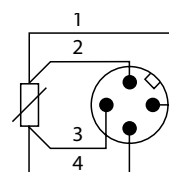
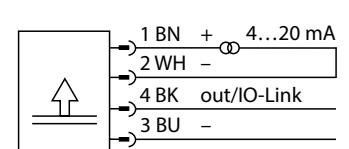

TP Series

- Accuracy
 - class A for temp. < 350 °C
 - class B for temp. > 350 °C
- Pt100 probe acc. to DIN EN 60751
- Vibration proof
- Connectable to TS, TT and TC series as well as IM34 and IMS
- Protection class IP67
- Mineral-insulated probes
- Bendable rod-type probe

The core element of the TP series is a Pt100 measuring resistor in 4-wire technology. All probes feature a standard M12 x 1 connection to the processing unit.



TP - **103A** - **G1/8** - **H1 1 4 0** - **L013**

TP Functional principle - **103A** Mechanical version - **G1/8** Process connection -

Design
TP temperature probe

Design

103A	processing unit with probe Ø 3 mm, process connection via standard thread accuracy class A
203A	compression fitting thermowell probe Ø 3 mm, accuracy class A
206A	processing unit with probe Ø 6 mm, process connection via clamping sleeve, accuracy class A
306A	cable probe Ø 6 mm
504A	with food-proof process connection Ø 4 mm, accuracy class A

Process connection

DN25	DN25 dairy screw connection DIN 11851 (only 504A)
CF	compression fitting or thermowell
G1/8	G1/8"-male thread (nur 103A)
TRI3/4	Tri-Clamp 3/4" (only 504A)

H1 1 4 1 Electrical connection - **L013** Probe length

Assignment

0	special assignment
1	standard assignment

Number of contacts

4	four
----------	------

Connector type

1	straight
----------	----------

Connector type

H1	M12 x 1 male
-----------	--------------

Probe length mm

L013	13 mm (only 103A)
L024	24 mm (only 103A)
L035	35 mm (only 504A)
L100	100 mm
L150	150 mm
L200	200 mm
L250	250 mm
L300	300 mm
L1000	1000 mm
L2000	2000 mm
L5000	5000 mm

Customized lengths on request!

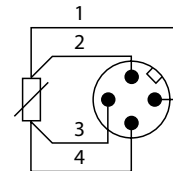

IM34

- Temperature measuring amplifiers, 1-channel, mounting on DIN rail
 - Input for Pt100/ Ni100 resistors in 2, 3 or 4-wire technology, variable resistors, thermocouples and millivolt signals
 - With intrinsically safe input circuits Ex ia, for zone 2, additional limit value relay required
 - Current output of 0/4...20 mA.
 - Galvanic isolation between input circuits and output circuits and supply voltage
 - Parametrized via PACTware™
 - HART® transmission
 - Universal operating voltage
 - Removable terminal blocks, reverse-polarity protected
- The IM34 temperature measuring ampli-

fiers are designed to evaluate temperature-dependent changes of Ni100/ Pt100 resistors, thermocouples B, E, J, K, L, N, R, S, T or low voltage in a range of -160...+160 mV and to output them as temperature linear current signals 0/4...20 mA. Types with relay output are additionally available for monitoring of limit values. The devices are parametrized via FDT/ DTM.



The following adjustments can be made: 2, 3, or 4-wire technology, measuring range, wire-break monitoring, output behaviour in the event of input circuit failure, internal or external cold junction compensation, temperature unit and

mode (resistance, thermocouple, low voltage and line compensation).

IM34 - 1 2 1 - Ex - R / 24VDC

IM34	Design	-	1	2	1	Number of channels	-	Ex	Device class	-
	<ul style="list-style-type: none"> IM interface module 34 temperature measuring amplifier 		<ul style="list-style-type: none"> Number of special outputs 1 special output e.g. alarm 	<ul style="list-style-type: none"> Number of channels on control side 1 output channel 2 output channels 4 output channels 	<ul style="list-style-type: none"> Number of channels on field side 1 output channel 			<ul style="list-style-type: none"> Ex associated equipment with intrinsically safe field current circuits (non-Ex no details) 		

R Output type /

- R relay switching output
- I current output 0/4...20 mA
- C computer parametrizable (FDT/DTM)
- D Display
- H HART®

24VDC Power supply

- 24 VDC power supply 24 VDC
- no universal power supply
- details unit

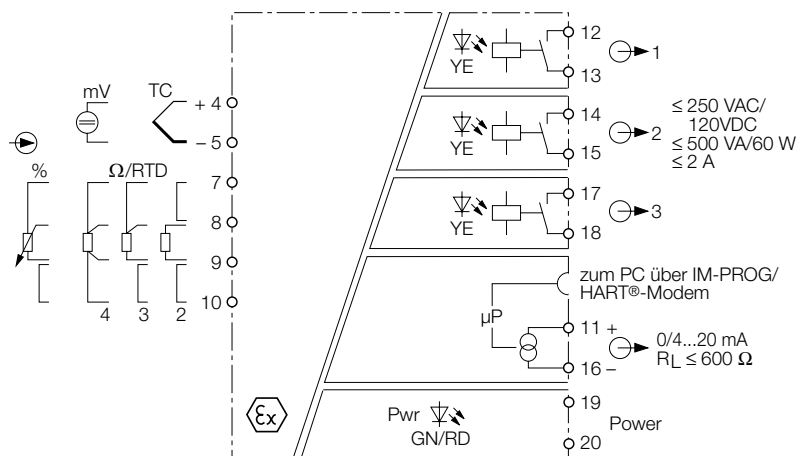

IMX12-TI

- Temperature measuring amplifier, single and dual channel, DIN rail mounting in a narrow 12.5 mm housing
- For connecting resistance thermometers in 2/3/4-wire circuit, thermocouples and millivolt signals
- Extensive international Ex approvals, Can be used in functionally safe circuits up to SIL2
- Versions with limit relays and intrinsically safe input circuits; can be mounted in zone 2
- Current output 4...20 mA as current source or sink parameterisable
- Galvanic isolation of input, output circuits and supply voltage
- Parametriebar via FDT/DTM e.g. PACT-ware

- Supply voltage range 10...30 VDC
- Removable terminal blocks, selectable as screw or spring-type terminals

The new interface device family IMX12 now also offers a temperature measuring amplifier. With a width of only 12.5 mm, the new IMX12-TI is the narrowest 2-channel EX temperature amplifier on the market. Besides the high channel density, the IMX12-TI offers very good precision and high functionality.

The temperature amplifier can be optimally adapted to the respective application via the established FDT/DTM technology.



As with all devices of the IMX12 family, the type of terminals can be selected. The Power Bridge system is optionally available to facilitate installation.

IMX12 - **TI02** - **2TCURTRD** - **21** - **CPR** / **24VDC** / **CC**

IMX12 Design	-	TI02 Functional principle	-	2TCURTRD Field side	-
IMX12 12.5 mm for intrinsically safe field signals		TI02 Temperature measuring amplifier		TCURTRD Resistance thermometer/thermocouple RTDR Resistance thermometer	

21 DCS side	-	CPR Special function	/	24VDC Power supply	/
I Current output 4...20 mA (source/sink) R Relay output		0 No special function C Computer parameterizable PR Power bridge system		24VDC 10...30 VDC	

CC Electrical connection
Blank Screw terminals SC Spring-type terminals

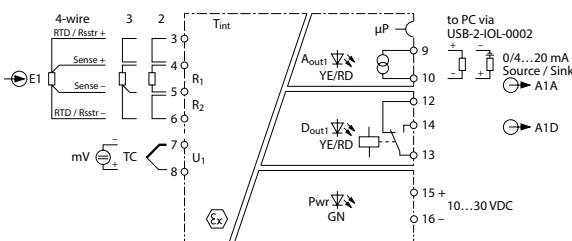
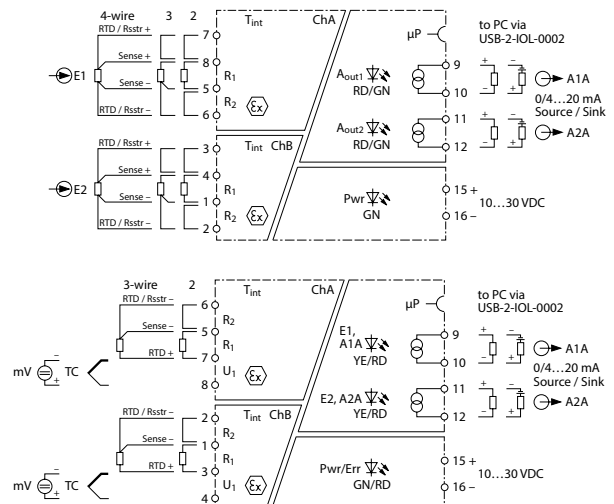

T-Gage

- Short response time of 75 ms
- User-friendly programming
- Compact design
- Rugged, fully encapsulated construction
- Available with cable or 5-pole M12 x 1 male
- Target need not be moved to be detected
- Alarm output for maximum signal
- Programmable for rising or dropping analog characteristic

The T-GAGE is a passively operating device, used for analog temperature measurement. It measures the temperature of objects in a defined range and emits a proportional voltage. Unlike other photoelectric sensors, the T-GAGE doesn't emit light but only measures the infrared radiation of objects. This sensor is thus perfectly suited for monitoring the temperature of hot objects, such as injection-moulded parts or bakery products, but also metals, bottles or rubbers. To avoid overload, the T-GAGE is also used for monitoring the temperature of conveyor-belt rollers. The sensor can also be used



in applications of the food industry to monitor cold objects, such as ice cream or milk products for example.

M18T B 6 Q

M18T Design **B Configuration of output and voltage** **6 D:S ratio**

M18T cylindrical thread, metal, 18 mm

B bipolar (NPN/PNP); 10...30 VDC
UP 0...30 V analog output and 1 PNP alarm output, 12...30 VDC
IP 4...20 mA analog output and 1 PNP alarm output, 12...30 VDC

Distance-Spot ratio
6 6:1
8E 8:1, encapsulated plastic housing
14 14:1, germanium lens

Q Electrical connection

- cable, 2 m, 5-pole
- Q** M12 x 1 male, 5-pole

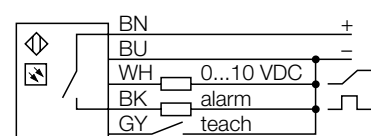
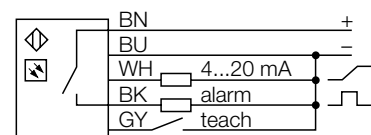
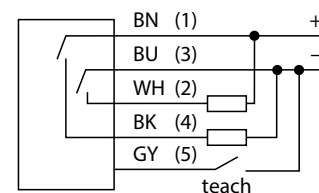

THW Series

- Thermowells
- Stainless steel 1.4404 (AISI 316L)
- Pressure-resistant up to 600 bar
- Probes fixed in place with compression fitting
- Rugged construction

THW thermowells are used to protect probes against environmental influences. They are available in different material qualities and for many requirements. Standard thermowells are made of 1.4404 stainless steel and designed for individual sensors.



THW - 3 - G1/8 - A4 - L013

THW Functional principle - **3** Probe diameter - **G1/8** Process connection -

Thermowell
THW

Probe diameter
3 3 mm
6 6 mm

Process connection
G1/8 G1/8" male thread
N1/8 1/8" NPT male thread
G1/4 G1/4" male thread
N1/4 1/4"-NPT male thread
G1/2 G1/2" male thread
N1/2 1/2"-NPT male thread
TRI3/4 3/4"-Tri-Clamp
DN25K DN25 dairy screw connection DIN 11851

A4 Material - **L013** Immersion depth

Material
A4 Stainless steel AISI 316L/1.4404

Probe length mm
L050 50 mm
L100 100 mm
L150 150 mm
L200 200 mm
L250 250 mm
L300 300 mm
Customized lengths on request!

CF Series

- Compression fittings for temperature probes with different process connections
- Stainless steel 1.4404 (AISI 316L)
- Pressure-resistant up to 100 bar
- Probes fixed in place with compression fitting



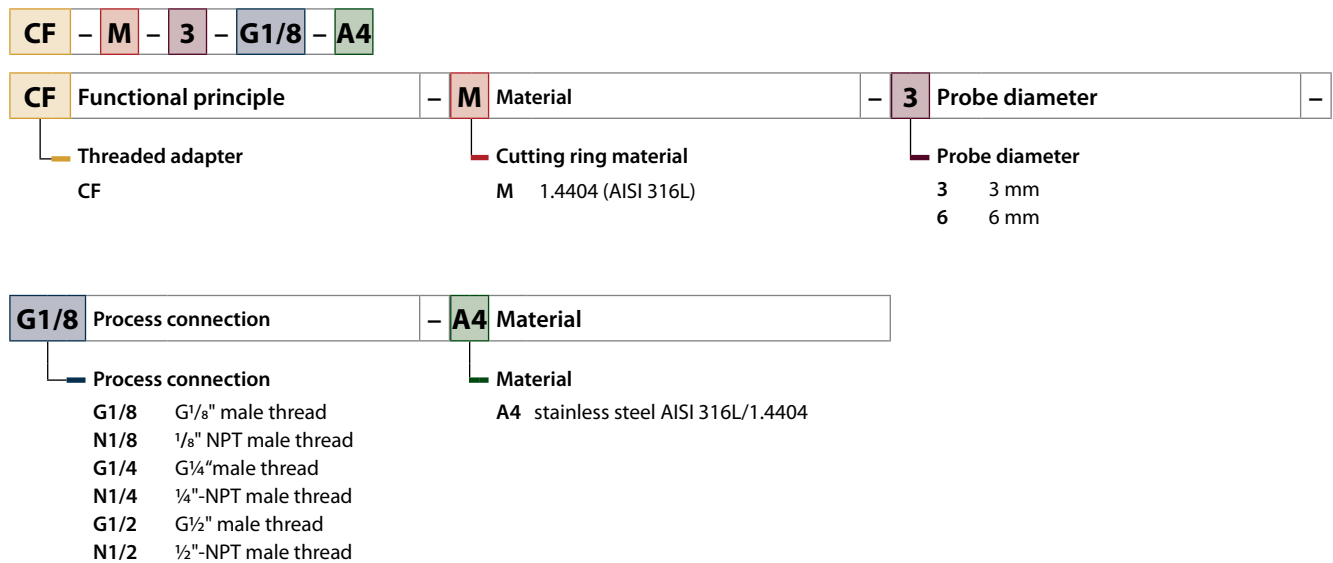
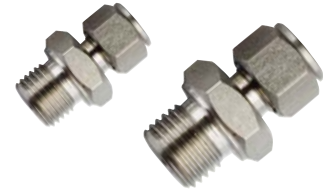





Compression fittings are always used when temperature probes have direct contact with a medium. A liquid and gas-tight connection is established by means of a compression fitting installed between the process and the environment.

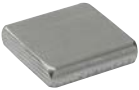

Accessories

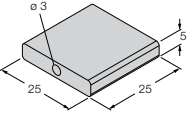
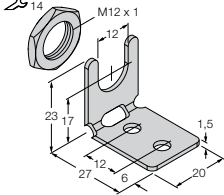
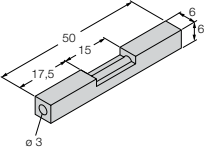
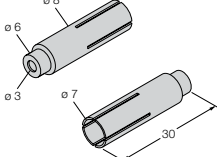
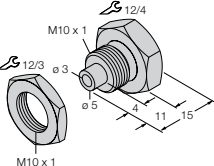
With the available product-specific accessories, the sensors can be mounted almost anywhere. We offer the right accessories for operation and installation of the temperature sensors.

This includes accessories for simple and safe mounting of temperature probes.

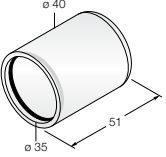
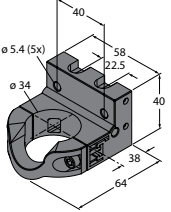
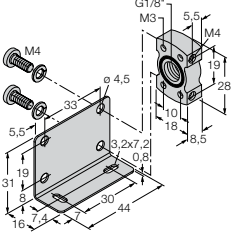
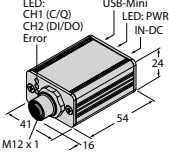
TP-MZ-001	TP-MZ-002	TP-MZ-003	TP-MZ-004	TP-MZ-005
				
weld-on-plate	wall mounting kit TP series	barrel holder	clamp sleeve	wall bushing
				
PTS-Cover	PTS-MB-34	PK-P-MZ-001	USB-2-IOL-0002	
				
Closure Cap for TS Series	Mounting Kit TP-103A	IO-Link USB Master		
				

Fluid Sensors Portfolio

Sensors for pressure, flow, temperature, level control and capacitive position sensing

In addition to pressure sensors, Turck offers an extensive portfolio of sensors for the monitoring of flow velocity, filling level as well as temperature and capacitive position sensing.

Flow sensors/Flow meters

The failure of flow leads, often and inevitably, in almost all applications of production and process technology to significant impairments and outages. The monitoring of the flow plays an essential role. Turck offers different flow monitoring systems from universal to the special use.



Temperature measurement

In order to operate machinery and equipment efficiently and safely, temperature has to be controlled continuously as a critical size in many industrial processes. In combination with numerous connection options and variable output signals, the Turck portfolio guarantees maximum flexibility in terms of pressure measurement



Level control

For level detection in liquids or solids, Turck offers special level sensors that detect levels according to the capacitive measuring principle or continuously monitor the filling level. Like all fluid sensors from Turck, the level sensors are also very robust, reliable and resistant to aggressive operating conditions.



Архангельск (8182)63-90-72
 Астана (7172)727-132
 Астрахань (8512)99-46-04
 Барнаул (3852)73-04-60
 Белгород (4722)40-23-64
 Брянск (4832)59-03-52
 Владивосток (423)249-28-31
 Волгоград (844)278-03-48
 Вологда (8172)26-41-59
 Воронеж (473)204-51-73
 Екатеринбург (343)384-55-89
 Иваново (4932)77-34-06

Ижевск (3412)26-03-58
 Иркутск (395)279-98-46
 Казань (843)206-01-48
 Калининград (4012)72-03-81
 Калуга (4842)92-23-67
 Кемерово (3842)65-04-62
 Киров (8332)68-02-04
 Краснодар (861)203-40-90
 Красноярск (391)204-63-61
 Курск (4712)77-13-04
 Липецк (4742)52-20-81
 Киргизия (996)312-96-26-47

Магнитогорск (3519)55-03-13
 Москва (495)268-04-70
 Мурманск (8152)59-64-93
 Набережные Челны (8552)20-53-41
 Нижний Новгород (831)429-08-12
 Новокузнецк (3843)20-46-81
 Новосибирск (383)227-86-73
 Омск (3812)21-46-40
 Орел (4862)44-53-42
 Оренбург (3532)37-68-04
 Пенза (8412)22-31-16
 Казахстан (772)734-952-31

Пермь (342)205-81-47
 Ростов-на-Дону (863)308-18-15
 Рязань (4912)46-61-64
 Самара (846)206-03-16
 Санкт-Петербург (812)309-46-40
 Саратов (845)249-38-78
 Севастополь (8692)22-31-93
 Симферополь (3652)67-13-56
 Смоленск (4812)29-41-54
 Сочи (862)225-72-31
 Ставрополь (8652)20-65-13
 Таджикистан (992)427-82-92-69

Сургут (3462)77-98-35
 Тверь (4822)63-31-35
 Томск (3822)98-41-53
 Тула (4872)74-02-29
 Тюмень (3452)66-21-18
 Ульяновск (8422)24-23-59
 Уфа (347)229-48-12
 Хабаровск (4212)92-98-04
 Челябинск (351)202-03-61
 Череповец (8202)49-02-64
 Ярославль (4852)69-52-93